

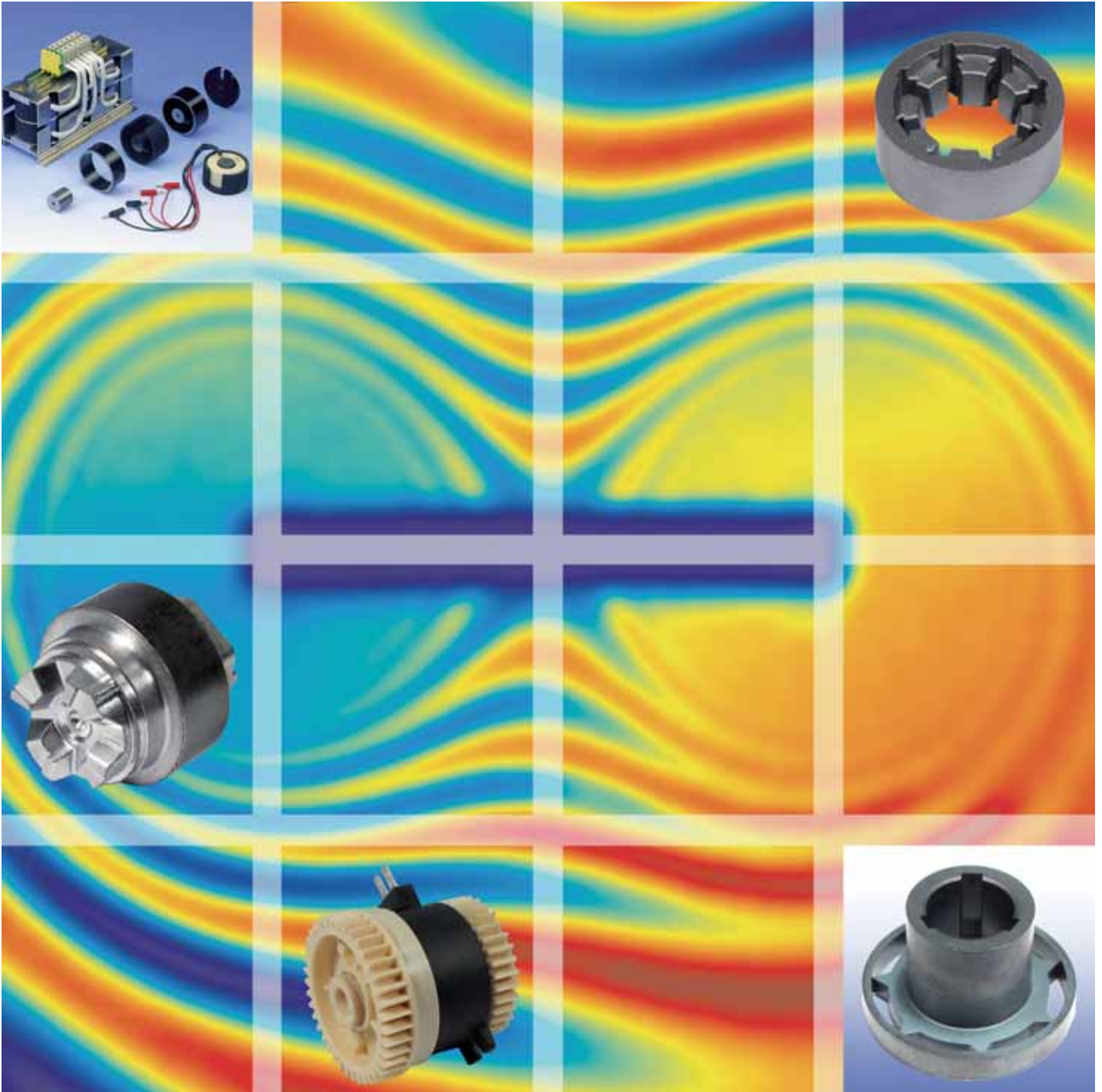

PM Soft Magnetic Materials





Soft Magnetics – Our Products a

GKN Sinter Metals, the global leader in PM technology, provides value to its customers through design innovation based on cooperative development and continuous process reliability in high volume production environments.

Among our core competences are the manufacturing of highly complex sintered components by classical powder pressing, metal injection moulding, as well as powder forging and the production of sintered filters and bearings. To open up new areas of industrial and automotive applications for PM components, we have focused our research and development activities on the manufacturing and processing of soft magnetic powders and sintered materials. Here we are succeeding in gradually optimising the magnetic, electrical and mechanical properties of our products so that we can manufacture even more energy-efficient components our customers in the future.





are Amazingly Attractive!

Unconventional designs of high performance parts and assemblies usually require a great degree of magnetic properties in conjunction with optimum material utilization. Generally, though, these designs cannot be implemented due to the prohibitive costs required in alternative manufacturing processes.

Since the use of powder metallurgical soft magnetic materials is still relatively unknown, the implementation of new components designs using this technology has been limited.

By using PM technology the previous limits can be redefined, thanks to an increased freedom of part design and a significant reduction of manufacturing costs. The implementation of net or near net shape and high density sintered components creates value-added benefits, both from a commercial and a technological perspective, to which end, customers in multiple industries can profit in cooperation with GKN Sinter Metals.



Sintered Soft Magnetic Materials

Applications of sintered soft magnetic materials (direct current in the frequency range <50 Hz) offer important economic advantages. Net or near net shape and high density manufacturing of the products leads to magnetic properties that are very close to those of fully dense materials.

Sintered materials are capable of independently modifying saturation induction and coercive force. In fully dense ferrous materials, the maximum or saturation induction is fixed and only the coercivity is variable.

This presents the possibility of "custom tailored" materials for each individual application.

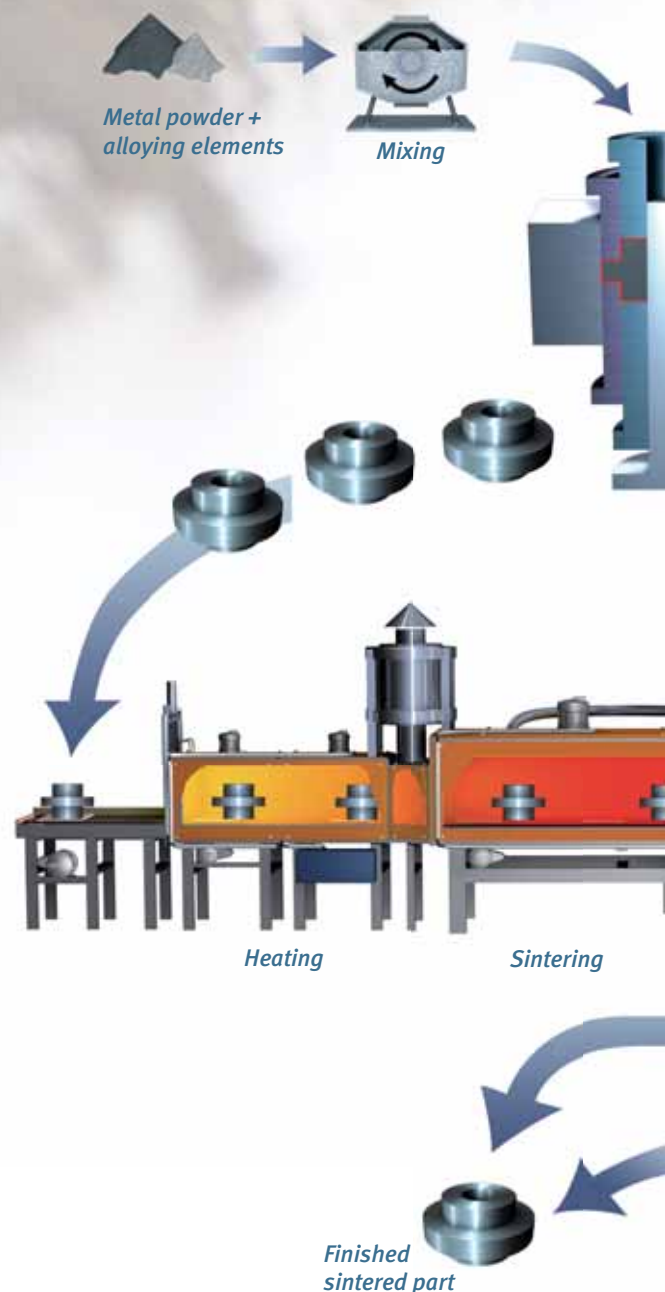

Materials	
100 % pure iron Fe	
Iron phosphorus FeP	· 0,45 % P
Iron silicon FeSi	· 3 % Si
Iron nickel FeNi	· 50 % Ni
Ferritic stainless steel	· 16 % Cr · 19 % Cr



1.) RAW MATERIAL

For the manufacture of soft magnetic products it is critical to use a material system that is appropriate to the specific requirements of the individual application. The soft magnetic properties, like induction and permeability, are dependant on the final density present in each component, which is determined by the densification of the powder by the compaction/pressing process.

2.) PRESSING

By using special presses with multi-level technology it is possible to manufacture products in the density range $>7.4 \text{ g/cm}^3$. This technology helps us to achieve a homogeneous density distribution which has a positive effect on the magnetic properties.

3.) SINTERING

For sintering the "green" compacts we use high temperature sintering in a 100% hydrogen atmosphere. This combination favours sintering and enhances the density of the product. The required furnaces are not standard in the PM industry - GKN Sinter Metals as a technological leader has at its disposal several manufacturing plants where such equipment is available.

4.) SECONDARY OPERATIONS

Secondary operations such as sizing (stress-relieving heat treatment necessary), deburring, machining, etc., can be applied after sintering if required.

APPLICATION:

- > Low frequency power $<50 \text{ Hz}$

FEATURES:

- > High saturation induction
- > Low coercivity
- > High permeability
- > Low residual magnetism
- > Corrosion resistance (ferritic stainless)

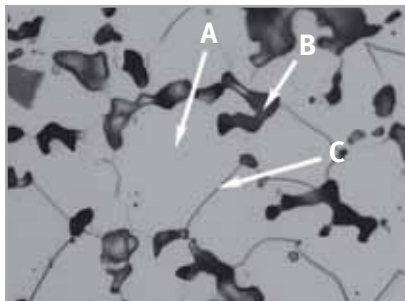

Microstructure - sintered material

A: particle B: pore C: grain boundary



Pressing

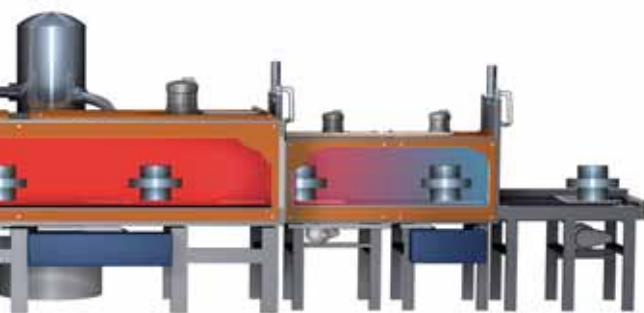

Cooling

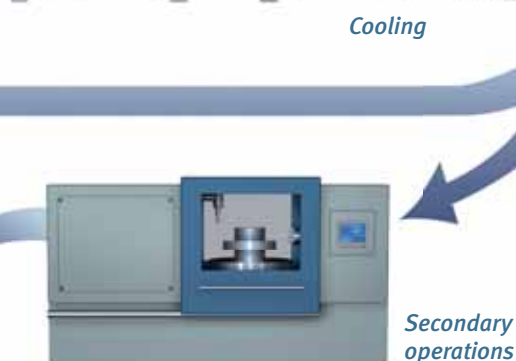

Secondary operations

Non-sintered Soft Magnetic Materials

Applications in alternating fields (>50 Hz) made from non-sintered soft magnetic materials (SMC → Soft Magnetic Composites) offer an attractive economic advantage. Due to the net or near net shape and high density design of the products the magnetic properties of transformer sheets are approached, but at less cost.

Particularly in the frequency range >2 kHz eddy current losses are smaller than in comparable transformer sheets.

In addition, for the development of new electrical engines the 3-dimensional magnetic flux is of high importance. These two properties can only be attained with PM SMC materials.

For applications such as coil cores where mainly eddy current losses are of interest and induction and permeability are less important, special materials are used in conjunction with an adapted process.

By applying various materials and with the development of innovative processes we have succeeded in covering a great frequency range and hence a wide spectrum of applications.

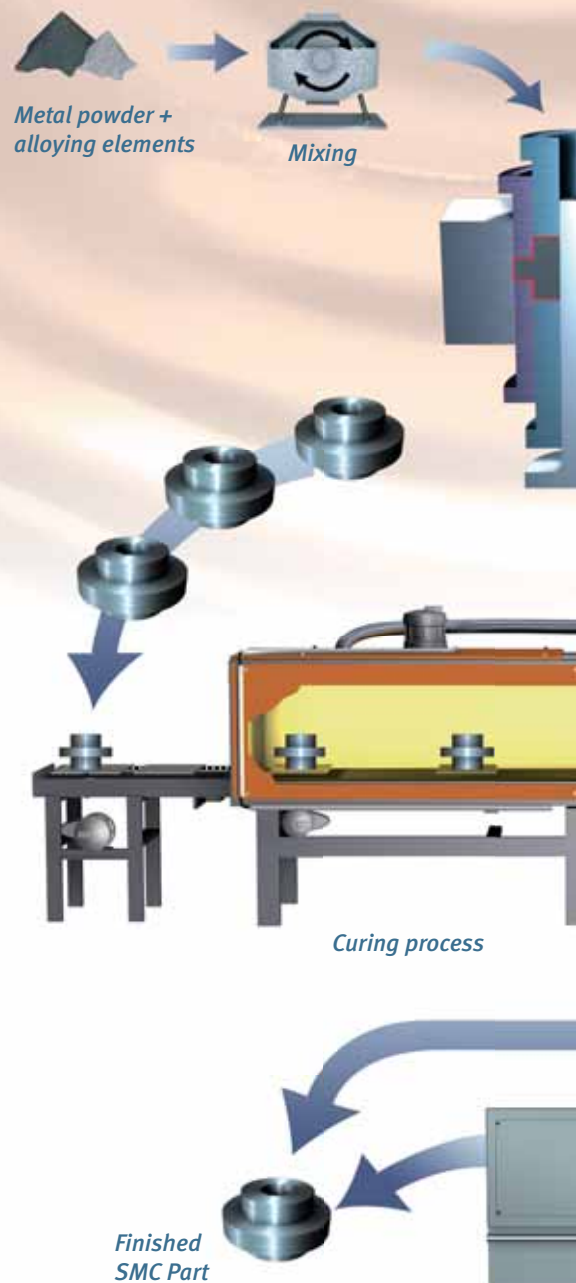

Materials
GKN SMC-A
GKN SMC-50L
GKN SMC-70H

als

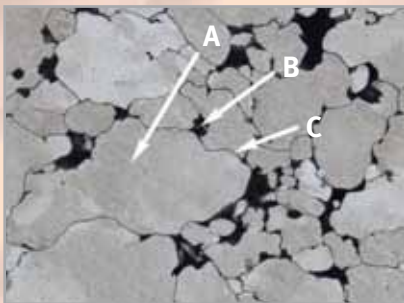

Microstructure – non-sintered material

A: particle B: pore C: grain boundary

Pressing

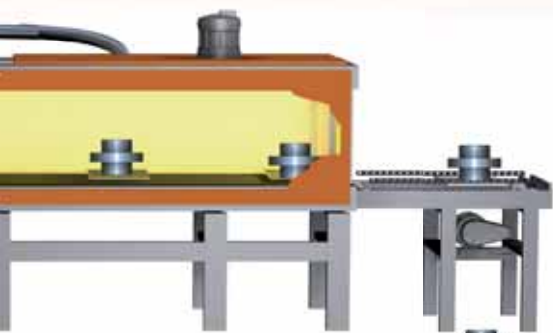

Secondary operations

1.) RAW MATERIAL

The raw material → **SMC (Soft Magnetic Composites)** is essentially composed of pure iron. The special feature of this material is that each particle is provided with an electrically insulating coating.

2.) PRESSING

Just as for the sintered materials, the powder is compacted in special presses, optimised for this process step, into the desired shape and density. Depending on the requirements of the application, SMC materials are manufactured in varying densities. Densities of up to 7.5 g/cm^3 are possible.

3.) CURING PROCESS

The subsequent "curing" process is performed in a special atmosphere and at a temperature $<700 \text{ }^\circ\text{C}$. The binder that has been blended with the raw material is hardened at a relatively low temperature to provide strength. At the same time sintering is avoided, so the isolating coating is not damaged and its insulating effect lost. The binder is ultimately responsible for the cohesion of the structure.

4.) SECONDARY OPERATIONS

After curing, subsequent machining is possible.

APPLICATIONS:

> High frequency power $>50 \text{ Hz}$

FEATURES:

- > High saturation induction
- > Low eddy current losses
- > High permeability $>500 \mu$ possible
- > Low residual magnetism

GKN – Support and Service

1.) CUSTOMER DRAWING

The customer's part drawing or design is usually not prepared with the specific aspects of manufacturing by the sintering technique in mind. Discussions between our engineering team and our customers are key to enable us to understand the function of the component and propose appropriate design modifications which are necessary for a sintering process.

2.) PROCESS-FRIENDLY PROPOSAL OF GKN

GKN provides the customer with a process-friendly proposal including a design which is suitable for sintering and the selection of a material customised for the application.

Components, densities and the resulting magnetic properties are attached to the quotation.

3.) SOLUTION FOR BEST PERFORMANCE

With the advantages of sintering technology it has become possible to develop magnetically optimised solutions. In current part designs and applications, the magnetic power losses are only reduced by minimizing connections. Through the use of certain alloying elements such as nickel or silicon, magnetic properties can be selectively affected.

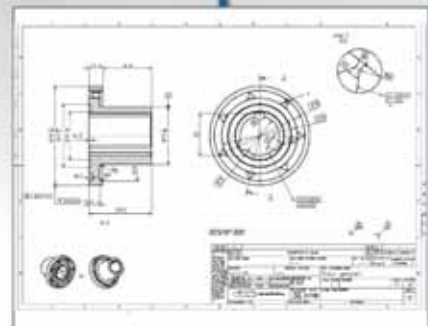
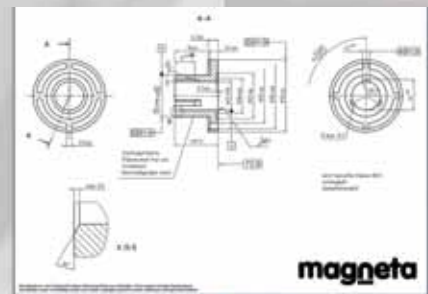



6.) COMPONENT AND APPLICATION

After completion of the test phase and approval by the customer, volume production is started. GKN Sinter Metals is capable of using standardized manufacturing processes, certified to latest industry requirements to meet the highest quality standards. This includes, of course, the opportunity for comprehensive process control which can be adapted to suit the given requirements of the manufactured component.



5.) DETERMINATION OF MAGNETIC PROPERTIES

The measurement of magnetic properties such as saturation induction, coercive force, permeability, hysteresis curve and eddy current loss is part of the fundamental analysis of the various sintered materials. These measurements are performed on standardized ring samples. Magnetic properties are monitored during production runs as well.



4.) PROTOTYPE MANUFACTURE

Prototypes are manufactured in-house on high precision machine tools. They are machined from raw materials blanks manufactured in-house from the same materials that are later used in volume production. This is the only way to obtain results on the function and the mechanical properties comparable to those of series product. All processing steps that are performed on a series product are also applicable to the prototype product.



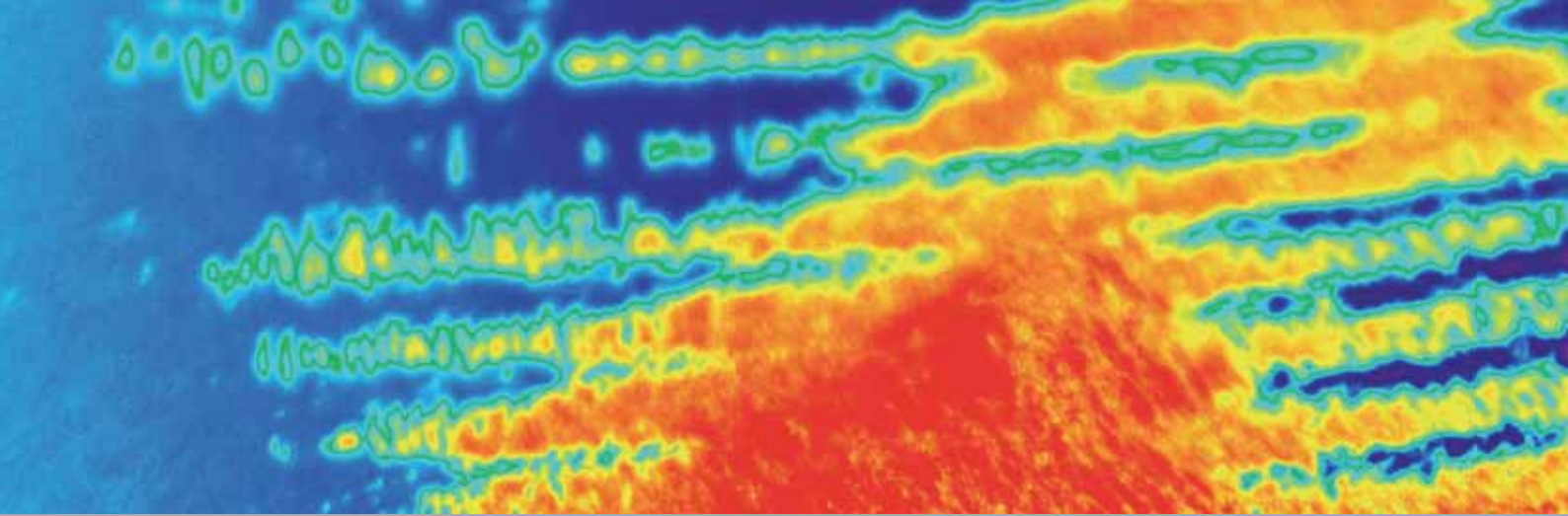

Non-sintered Soft Magnetic Materials (SMC)¹⁾

Designation	Typical Properties ²⁾						
	Chemical composition	Coercivity H _c [A/cm]	Saturation induction B _{max} [T]	Permeability	Remanence B _r [T]	Eddy current losses 1T/50 Hz [W/kg]	Eddy current losses 1T/1 kHz [W/kg]
GKN SMC-A	Isolated Fe	266	1.52	485	0.251	6.08	205
GKN SMC-50L	Isolated Fe	105	0.95	370	0.059	9.25	302
GKN SMC-70H	Isolated Fe	268	1.41	447	0.237	9.87	230

¹⁾ Soft Magnetic Composites ²⁾ tested on standard samples

Sintered Soft Magnetic Materials

Standards			Typical Properties ³⁾								
DIN EN 10331	DIN 30910	MPIF	Nominal composition	Density [g/cm ³]	Coercivity H _c [A/cm]	Saturation induction B _{max} [T]	Permeability	Hardness HB	R _m [Mpa]	R _{po,2} [Mpa]	A [%]
S-Fe-170	D 00	FF-0000-20X	Fe	7.1	140	1.44	3,340	50	180	80	12
S-Fe-165	E 00	FF-0000-20Y	Fe	7.3	100	1.61	4,250	60	210	100	16
S-FeP-150	D 35	FY-4500-17X	Fe _{0,45} P	7.1	110	1.45	4,210	110	350	250	10
S-FeP-130		FY-4500-17Y	Fe _{0,45} P	7.4	70	1.7	6,410	125	380	270	14
S-FeNi-20		FN-5000-5Z	Fe ₅₀ Ni	7.8	16	1.3	19,550	80	310	220	20
S-FeSi-80		FS-0300-12X	Fe ₃ Si	7.2	75	1.6	4,510	140	380	275	15
	C 42	SS-430L	Fe ₁₆ Cr	6.7	320	1.06	320	70	300	170	12
	D 42	SS-430L	Fe ₁₆ Cr	7.0	280	1.17	370	90	340	200	16
	C 43	SS-410L	Fe ₁₂ Cr	6.7	390	1.15	340	85	280	150	10
	D 43	SS-410L	Fe ₁₂ Cr	7.0	330	1.23	410	95	320	190	14

³⁾ Fe [wt-%] balanced ⁴⁾ C; Co [wt-%] > 0.1

Applications

Non-sintered soft magnetic materials (SMC)



Stator pole and base plate:
for high efficiency water pumps in dishwashers

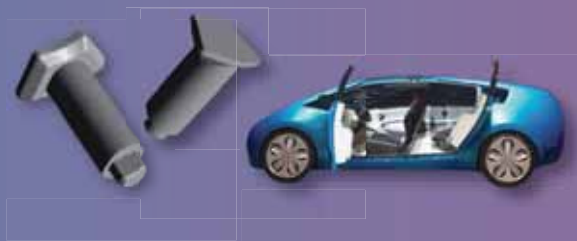

Stator pole for brushless DC engine:
for high efficiency cooling pumps of hybrid vehicles



Tensile strength R_m [Mpa]	Density [g/cm ³]	Application
150	7.45	High frequency soft magnetic applications; BLDC Motors; Transversal Flux Machinery; Transformers
100	6.8	
100	7.2	

Chemical Composition ⁴⁾						Application
E [Gpa]	P [wt-%]	Ni [wt-%]	Si [wt-%]	Cr [wt-%]	Others [wt-%]	
150	< 0.1	< 0.1	< 0.1	< 0.1	< 0.5	Applications in low frequency power and permanent magnet systems
165	< 0.1	< 0.1	< 0.1	< 0.1	< 0.5	
150	0.45	< 0.1	< 0.1	< 0.1	< 0.5	Applications in low frequency power with fast response and permanent magnet systems
175	0.45	< 0.1	< 0.1	< 0.1	< 0.5	Applications in low frequency power with fast response
150	< 0.1	50	< 0.1	< 0.1	< 0.5	
160	< 0.1	< 0.1	3	< 0.1	< 0.5	Applications in medium frequency power (<1000 Hz) with fast response
125	< 0.1	< 0.1	< 0.1	18	< 1	Applications in low frequency power and permanent magnet systems with high corrosion resistance
140	< 0.1	< 0.1	< 0.1	18	< 1	
125	< 0.1	< 0.1	< 0.1	13	< 1	
140	< 0.1	< 0.1	< 0.1	13	< 1	

R_m : Tensile strength R_e : Yield strength A: Elongation E: Young's modulus

Sintered soft magnetic materials



Electromagnetic clutches for ATMs:
clutch unit for the interruption of the torque



Electromagnetic valve (pole piece):
valve unit serving to interrupt the oil flow



About GKN Sinter Metals

GKN Sinter Metals – a wholly owned subsidiary of U.K.-based GKN plc, a global industrial company – is the world's largest producer of precision powder metal products. With a focus on superior delivery, quality and total solutions, the company offers extensive technical expertise in design, testing and various process technologies. GKN Sinter Metals offers a full range of more than 10,000 complex shape, high strength products for the automotive, commercial vehicle, home appliance, lawn and garden, office equipment, power tool, recreational vehicle and process industry markets.

The company's global footprint spans more than 13 countries across five continents. GKN Sinter Metals is in close proximity to its customers with more than 30 global locations and a workforce of approximately 5,500 employees.

For more information about GKN's world of solutions visit www.gknsintermetals.com

Production Plants

Argentina

GKN Sinter Metals de Argentina S.A.

Ruta Nac. 5 Km. 159,5
(B6622GKA) Chivilcoy – Bs. As.
Argentina

Phone: *54-11-5368-3700
E-mail: infoargentina@gknsintermetals.com

Brazil

GKN Sinter Metals Ltda.

Av. Emancipação, 4.500 - Santa Esmeralada
CEP 13186-542
Hortolandia – SP – Brazil

Phone: *55-19-2118-9400
E-Mail: infobrazil@gknsintermetals.com

Canada

GKN Sinter Metals – St. Thomas Ltd.

7 Michigan Boulevard
St. Thomas, Ontario
Canada N5P 1H1

Phone: *1-519-631-4880
E-mail: infona@gknsintermetals.com

China

GKN Sinter Metals – Danyang

Number 7 Mechanical Industry Park
Danyang Development Zone
Danyang,
China

Phone: *86-511-86-885-556
E-mail: infochina@gknsintermetals.com

Germany

GKN Sinter Metals Engineering GmbH

Krebsöge 10
42 477 Radevormwald
Germany

Phone : *49 2191-693-0
E-mail : infogermany@gknsintermetals.com

GKN Sinter Metals Filters GmbH

Dahlienstraße 43
P.O.Box 1520
42 477 Radevormwald
Germany

Phone: *49 2195-609-27
E-Mail: feedback@gkn-filters.com

GKN Sinter Metals GmbH, Bad Langensalza

(MIM-Plant)
Am Fliegerhorst 9
99 947 Bad Langensalza
Germany

Phone: *49 (0) 3603 8959-0
E-mail: infomim@gknsintermetals.com

India

GKN Sinter Metals Ltd.

146, Mumbai Pune Road
Pimpri, Pune 411 018
Maharashtra, India

Phone: *91-20-2742-6261, 6262, 6263
E-mail: infoindia@gknsintermetals.com

Italy

GKN Sinter Metals SpA

Fabrikstraße 5
39 031 Bruneck (BZ)
Italy

Phone: *39-0474-570211
E-mail: infoitaly@gknsintermetals.com

North America

GKN Sinter Metals

3300 University Drive
Auburn Hills, Michigan 48326-2362
USA

Phone: *1-248-371-0800
E-mail: infona@gknsintermetals.com

South Africa

GKN Sinter Metals – Cape Town

P.O.Box 156
Snacks Circle
Bellville, 7530
South Africa

Phone: *27-21-951-2311
E-mail: infoafrica@gknsintermetals.com

GKN Sinter Metals Sales Offices Worldwide

China

E-mail : infochina@gknsintermetals.com

France

E-mail: infofrance@gknsintermetals.com

Japan

E-mail: infojapan@gknsintermetals.com

Korea

E-mail: infokorea@gknsintermetals.com

Spain

E-mail: infospain@gknsintermetals.com

Sweden

E-mail: infosweden@gknsintermetals.com

United Kingdom

E-mail: infouk@gknsintermetals.com